

SCSA TSP H CHASSIS



SAFETY WARNING: Before commencing any work or modifications on your rifle, make sure your rifle is UNLOADED. Before starting with the assembly procedure of this product, REMOVE the BOLT and MAGAZINE from the rifle.

ASSEMBLING YOUR SCSA TSP H CHASSIS

Step 1: Remove the action from the current stock/chassis

1. Loosen and remove the action screws holding the action in.
2. Pull the action away from the stock.

Step 2: Install the receiver/action to the chassis inlet

1. Invert receiver/action and align TSP H chassis inlet above it.
2. Insert and lightly secure the front and rear action screws.
3. Torque the rear action screw to spec, then follow with the front action screw.

Step 3: Install trigger guard

1. Slot trigger guard into the inlet ensuring the trigger guard is homed towards the buttstock. Secure with provided screws.
2. Before moving onto the next step, test the magazine fitment into the chassis. The trigger guard is designed to adjust to cater for variances in AICS magazine.
3. Install A2 grip onto trigger guard with ¼"x1" fastener.

Step 4: Install buffer tube & buttstock

The TSP H is compatible with AR buffer tubes to allow for a wide selection of buttstocks.

1. Install the buffer tube (sold separately) into the rear thread of the inlet.
2. Retain the buffer tube with the M3x3mm grub screw.
3. Install buttstock (sold separately) over the buffer tube.



SOUTHERN CROSS SMALL ARMS

HOWA 1500 LA

Want to show off your rifle or have a question? Head on over to our Facebook, Instagram or email us at info@scsa-au.com



WHAT IS IN THE BOX?

- SCSA TSP H Chassis - chassis Inlet & trigger guard - requires assembly
- Chassis fasteners
- 1 * A2 grip with fastener
- Instruction manual – 30-09-2022

TOOLS REQUIRED

- 5mm hex key (wrench) metric threaded actions – action and chassis fastener
- 3 / 16" hex key (wrench) SAE threaded actions – A2 grip fastener
- 3mm hex key (wrench) – trigger guard fastener
- 2.5mm hex key (wrench) – buffer tube retaining fastener
- Torque wrench up to 30 N.m (265 in.lb)
- Loctite® 243-Blue medium strength or equivalent

SLING STUD INSTALLATION

Your TSP H also comes with a sling stud which you can mount on the end of the forend.

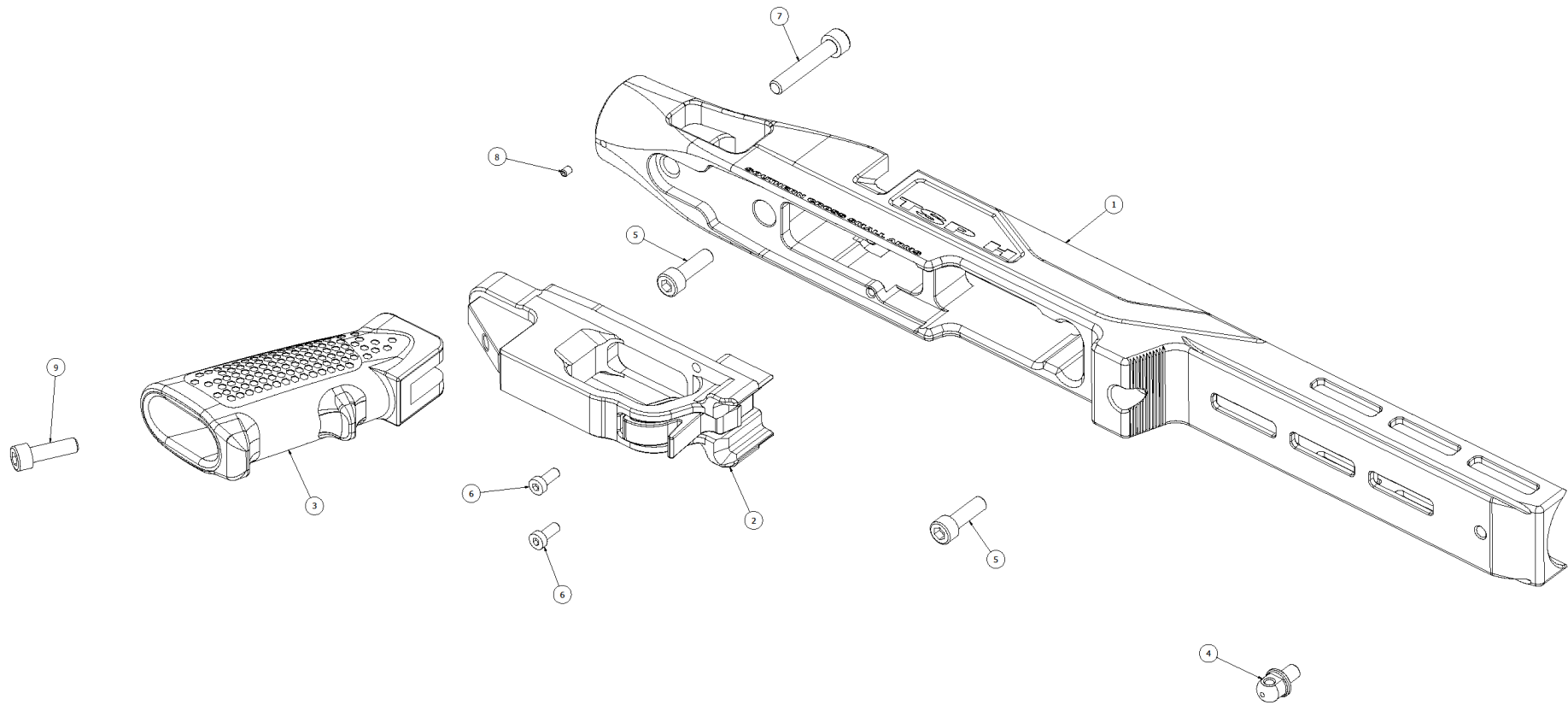

FIG 1

FIG 1 – TSP H CHASSIS				
ITEM	QTY	TORQUE	PART ID	DESCRIPTION
1	1	-	ILH05	CHASSIS INLET
2	1	-	TG05	TRIGGER GUARD AICS
3	1	-	A2 GRIP	GRIP
4	1	-	TSPHSS	SLING STUD
5	2	See Action Torque	M6 X 20mm SHCS	ACTION SCREWS
6	2	1.7N.m / 15in.lb	M4 x 10mm LOW HEAD SHCS	TRIGGER GUARD SUPPORT SCREWS
7	1	11N.m / 97.35in.lb	M6 x 35mm SHCS	TRIGGER GUARD SCREW
8	1	-	M3 GRUB SCREW	BUFFER TUBE RETAINING SCREW
9	1	-	¼" x 1" SHCS	GRIP SCREW

ACTION TORQUE:

Most HOWA 1500 actions respond well to torque setting of 6.22 N.m to 7.35 N.m (55 in.lb to 65 in.lb). Begin at the lower end and creep up in small increments, through experiment determine the ideal torque setting for your rifle.