

# SCSA TSP X CHASSIS



**SAFETY WARNING:** Before commencing any work or modifications on your rifle, make sure your rifle is UNLOADED. Before starting with the assembly procedure of this product, REMOVE the BOLT and MAGAZINE from the rifle.

## ASSEMBLING YOUR SCSA TSP X CHASSIS

### **Step 1: Remove the action from the current stock/chassis**

1. Loosen and remove the action screws holding the action in.
2. Pull the action away from the stock.

### **Step 2: Install the receiver/action to the chassis inlet**

1. Invert receiver/action and align TSP X chassis inlet above it.
2. Insert the grub screw and fasten against the recoil lug.
3. Insert and lightly secure the front and rear action screws.
4. Torque the rear action screw to spec, then follow with the front action screw.

### **Step 3: Install trigger guard and front adapter**

1. Slot trigger guard into the inlet ensuring the trigger guard is homed towards the buttstock. Secure with provided screws.
2. Attach forward adapter with the provided screws.
3. Before moving onto the next step, test the magazine fitment into the chassis. The trigger guard is designed to adjust to cater for variances in AICS magazine.

### **Step 4: Install buttstock and forend**

1. Secure butt stock to chassis inlet with the provided screw
2. Secure forend to chassis inlet with the provided screws



# HOWA M1500 LA (3.715")

Want to show off your rifle or have a question? Head on over to our Facebook, Instagram or email us at [info@scsa-au.com](mailto:info@scsa-au.com)



## WHAT IS IN THE BOX?

- SCSA TSP X Chassis - Buttstock, Chassis Inlet, Forend, Trigger Guard and Forward Magazine Adapter - requires assembly
- Chassis Fasteners
- 3 \* Spacers for extra LOP
- 1 \* A2 grip with fastener
- Instruction manual – 23-02-2021

## TOOLS REQUIRED

- 6mm hex key (wrench) – Buttstock fastener
- 5mm hex key (wrench) Metric Threaded Actions – Action and chassis fastener
- 3 / 16" hex key (wrench) SAE Threaded Actions – A2 grip fastener
- 4mm hex key (wrench) – Buttpad fastener
- 3mm hex key (wrench) – Grub screw & trigger guard fastener
- Torque wrench up to 30 N.m (265 in.lb)
- Loctite® 243-Blue medium strength or equivalent

## ADJUST TO SUIT YOUR NEEDS

### **Cheek rest yaw adjustment**

1. Loosen cheek riser levers and detach cheek rest assembly.
2. Loosen screws from plastic cheek component.
3. Adjust yaw up to 7 degrees in either direction.
4. Tighten screws to secure adjustment.

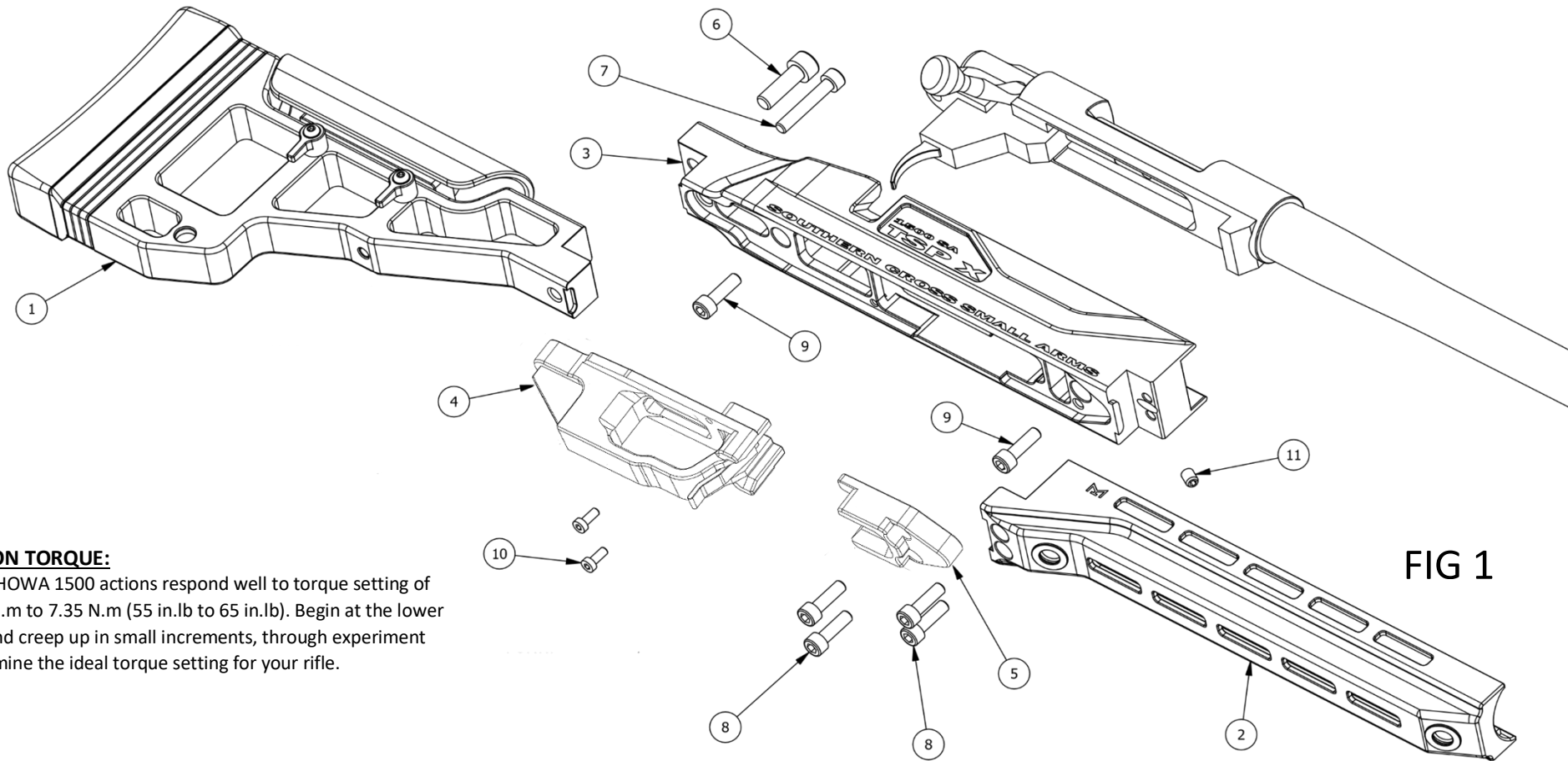

FIG 1

**ACTION TORQUE:**

Most HOWA 1500 actions respond well to torque setting of 6.22 N.m to 7.35 N.m (55 in.lb to 65 in.lb). Begin at the lower end and creep up in small increments, through experiment determine the ideal torque setting for your rifle.

FIG 1 - TSP X CHASSIS				
ITEM	QTY	TORQUE	PART ID	DESCRIPTION
1	1	-	BS02	BUTTSTOCK ASSEMBLY
2	1	-	FE00	FOREND ASSEMBLY
3	1	-	IL05	CHASSIS INLET
4	1	-	TG05	TRIGGER GUARD SA AICS
5	1	-	FA05	FORWARD SA AICS ADAPTER
6	2	22N.m / 194.7in.lb	M8 x 25mm SHCS	FOLDING MECH/BUTTSTOCK SCREW
7	1	11N.m / 97.35in.lb	M6 x 35mm SHCS	TRIGGER GUARD SCREW
8	4	16.5N.m / 146in.lb	M6 x 20mm SHCS	FORWARD ADAPTER / FOREND SCREWS
9	2	See Action Torque	M6 X 20mm SHCS	ACTION SCREWS
10	2	1.7N.m / 15in.lb	M4 x 10mm LOW HEAD SHCS	TRIGGER GUARD SUPPORT SCREWS
11	1	5N.m / 44.25in.lb	M6 X 16mm SET SCREW	RECOIL LUG CLAMPING SET SCREW